

EPRI

ELECTRIC POWER
RESEARCH INSTITUTE

Grid Transformation

Liang Min, EPRI

EPCC Workshop, Altea, Spain

May 22nd 2011

Tomorrow's Power System

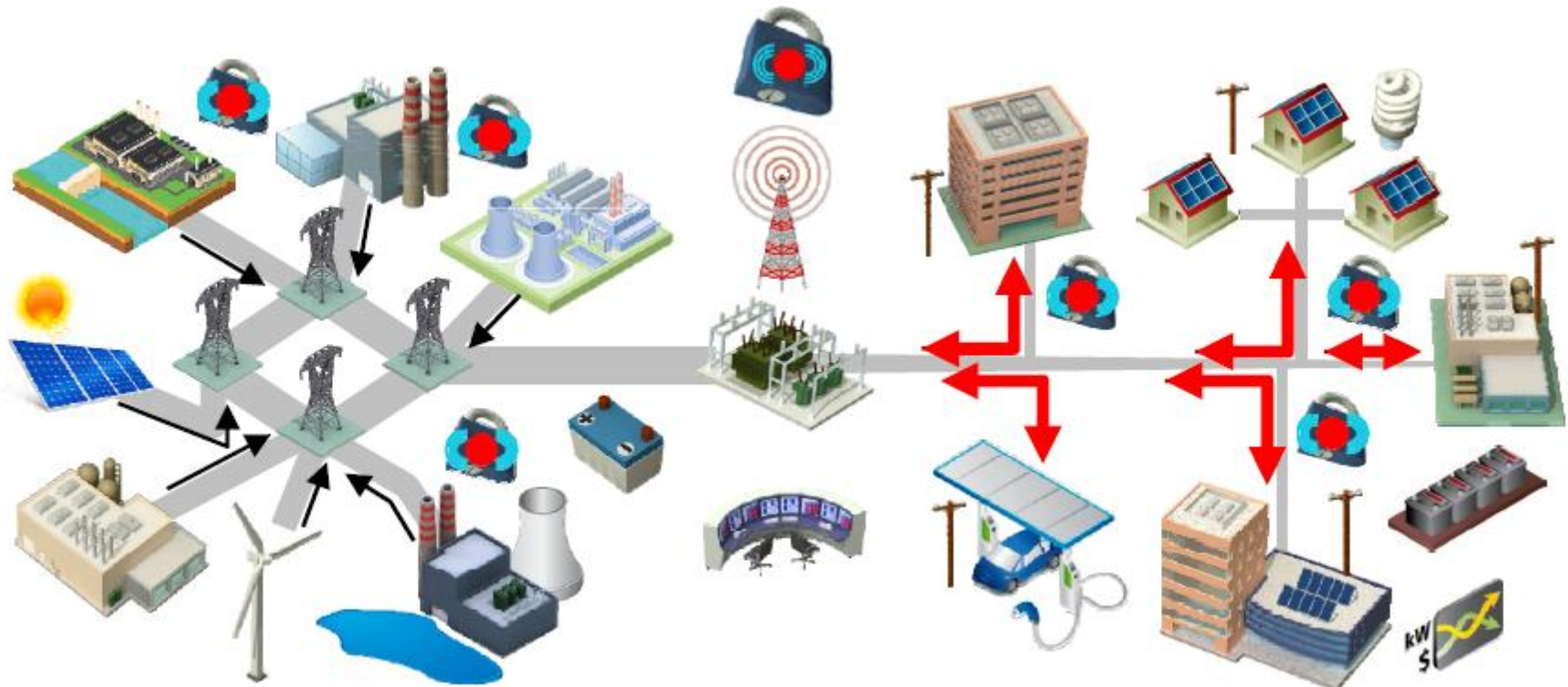

Changes We Area Facing...

- Variable Generation – The NERC predicts that **200 GW** of variable generation will be added by 2020.
- Demand Response – In a recent auction, PJM received **17%** of their requested capacity in the form of demand response and energy efficiency.
- Electric Vehicles – By 2030, it is anticipated that there will be more than **20 million** electric vehicles connected to the grid at various times.
- Smart Meters – There is a potential for as many as **80%** of the approximately **140 million** meters in the U.S. to be converted by 2030.
- Distributed Generation – Photovoltaic power generation systems are now in place on over **70,000** roof tops in the U.S., and those installations are growing at over **10%** per year.
- PMUs –DOE announced Smart Grid Investment Grants (SGIGs) to install over **850** PMUs in next three years.
- Communications – The phenomenal proliferation of electronic communications and information technology in all spheres of life and sectors of industry are extending into the electric power system.

Conceptual Approach

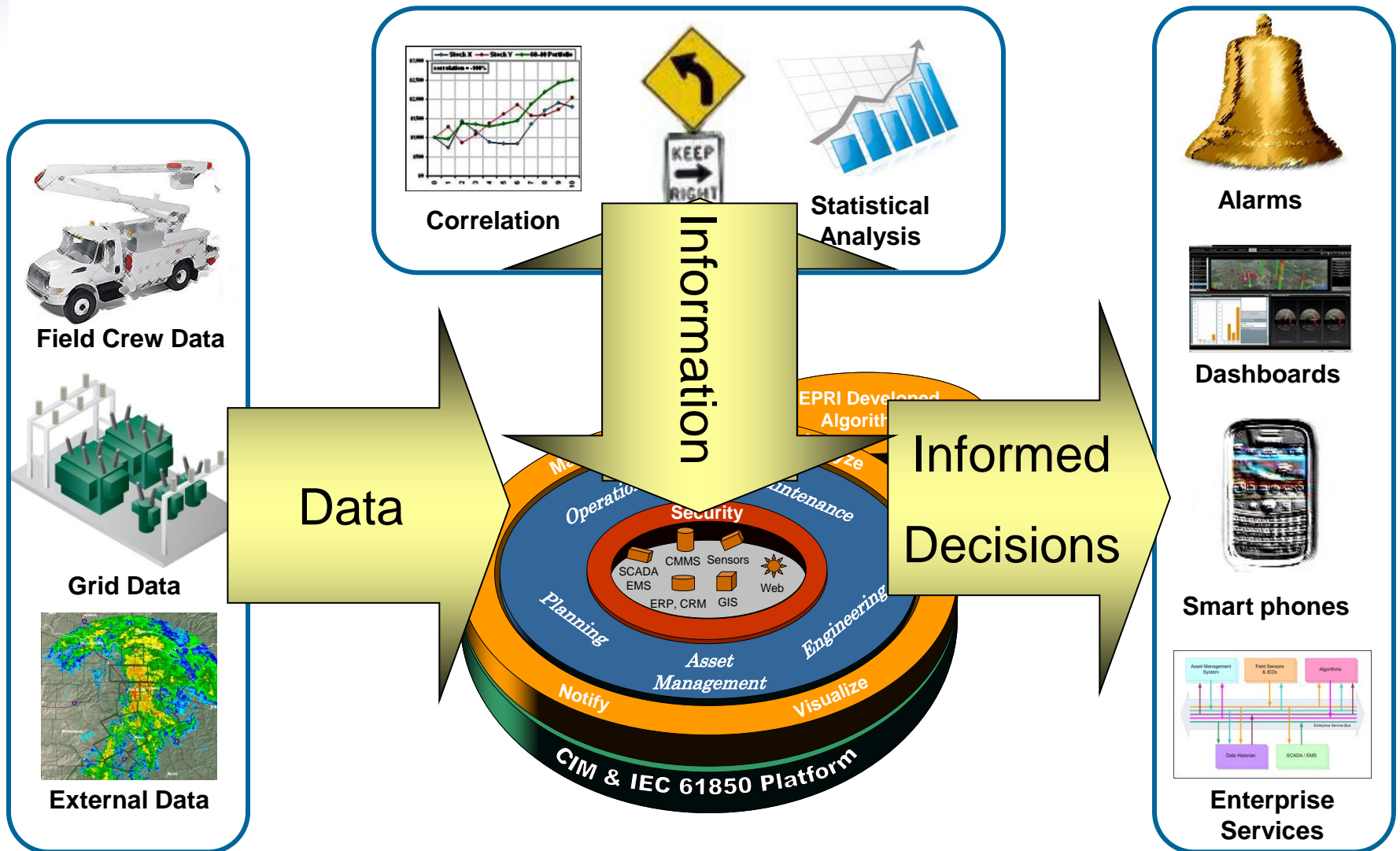

Four core research areas are being proposed

- Seamless geospatial three phase power system model concept
- Seamless power system analytics requirements development
- Integrated energy management system coupled with the above analytics and grid measurements
- Setting-less protection methods and Advanced Control Functions

Seamless geospatial three phase power system model concept

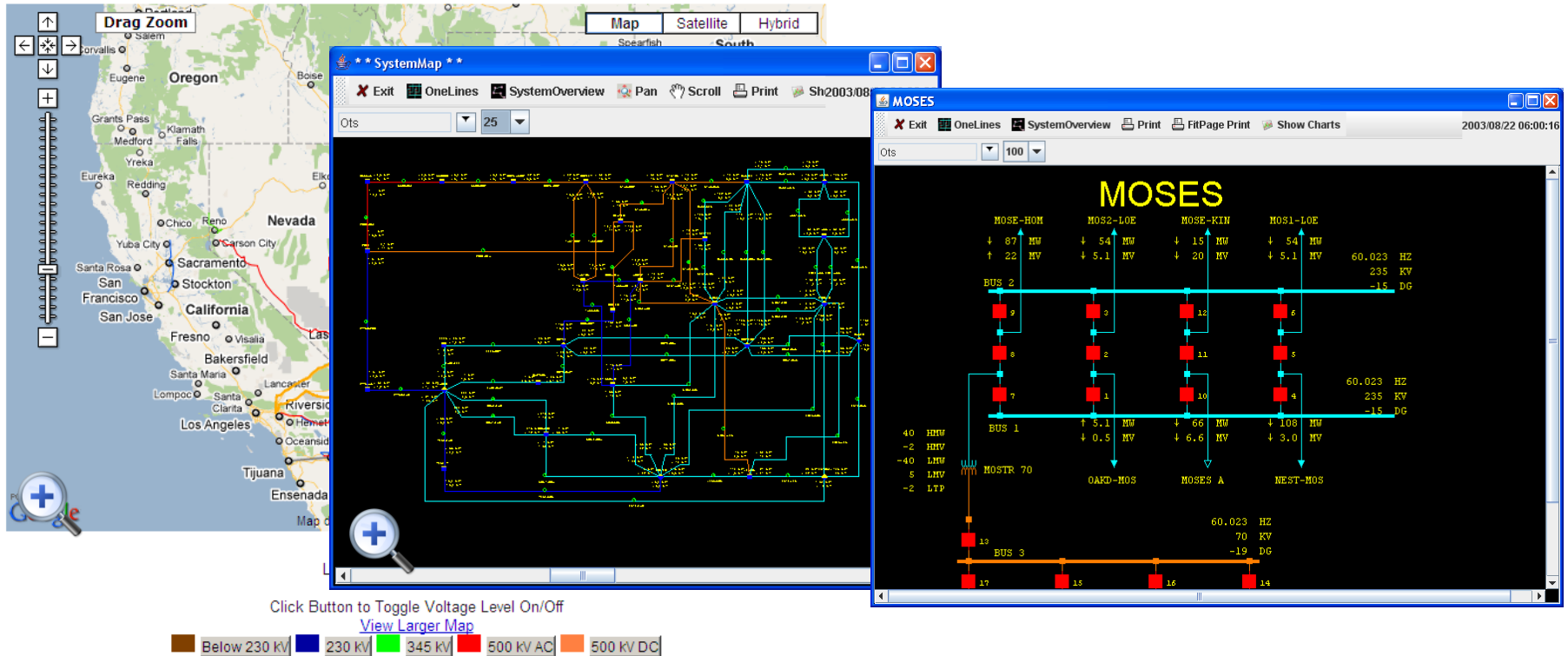

- The innovation will be in the database structure that can automatically and seamlessly adjust the data based on
 - Geography
 - Time scale
 - Level of analysis

Seamless geospatial three phase power system model concept

- Integration of Traditional and Non-Traditional Data

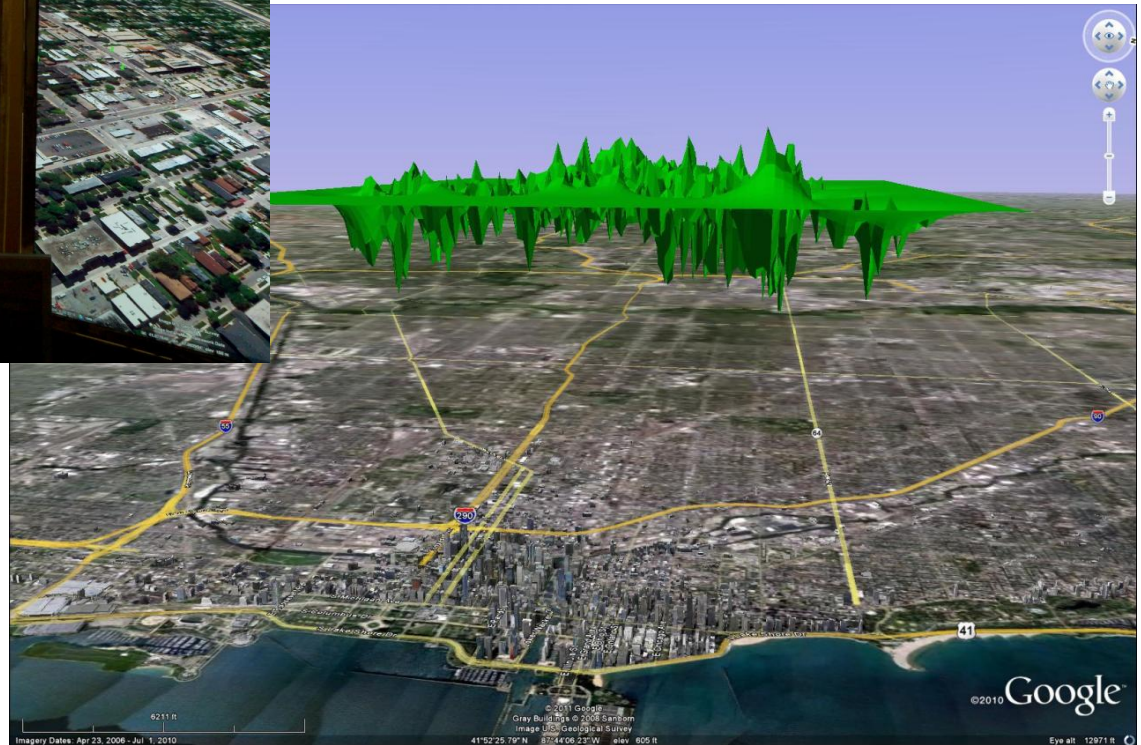

Seamless power system analytics

- The innovation is in the application linkage with the proposed comprehensive power system model and the application redevelopment that supports the proposed seamless analytics.
- The other innovation is in the investigation of “how” the analytics can be performed and expedited through the use of new computational processing.

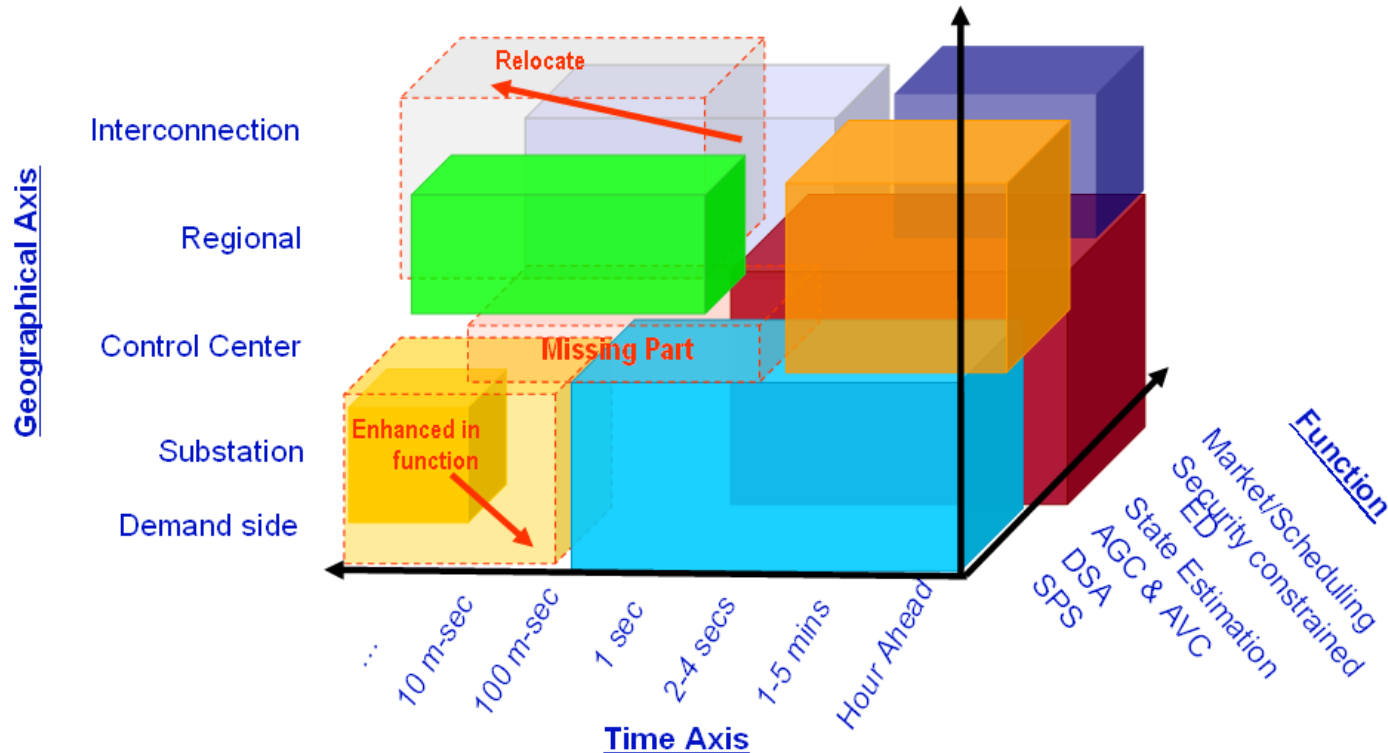

Seamless power system analytics - Synchrophasor Enabled Smart Applications

Voltage Stability

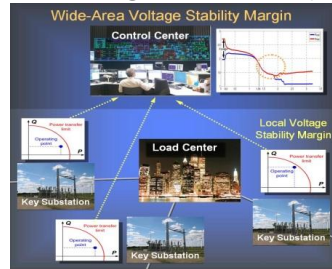

State Measurement



Operating Boundary

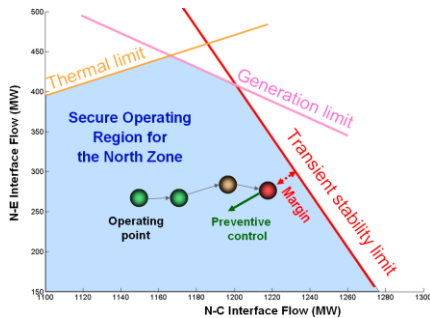

Phasor Measurement Units in North American Power Grid

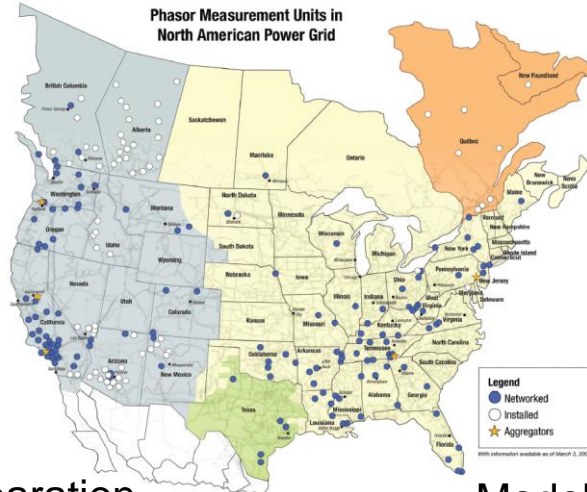

Visualization

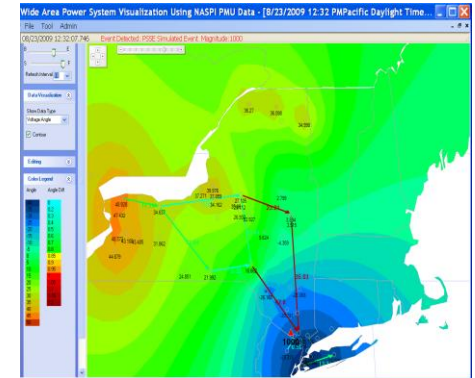

Control Separation

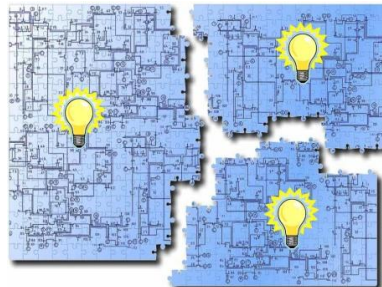

Model Validation

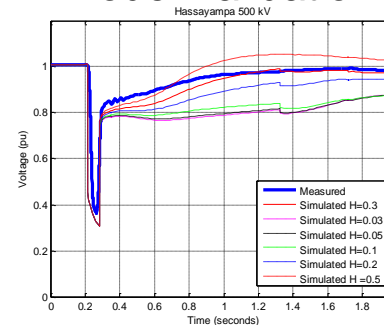

Integrated energy management system coupled with the above analytics and grid measurements

Sense → Monitor → Assess → Act → Sense.

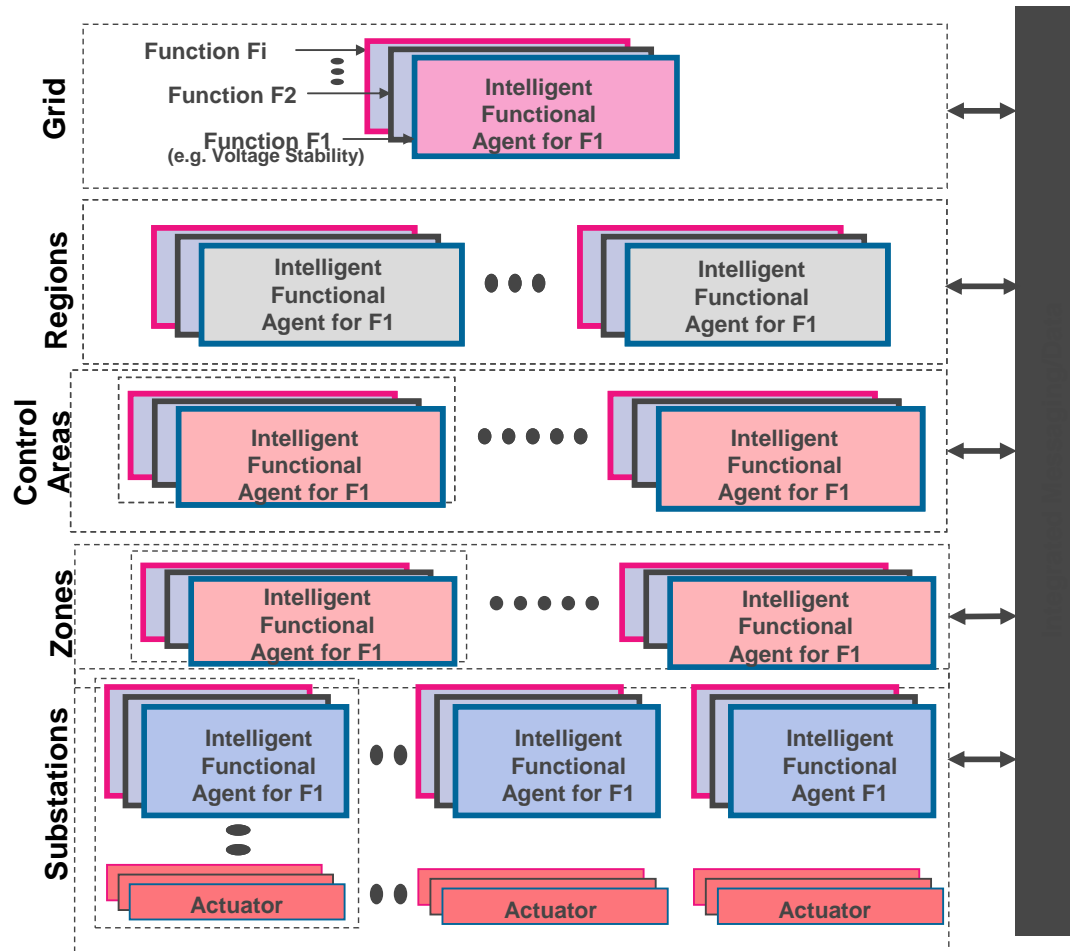

Source: EPRI Report 1011667, Transmission Fast Simulation and Modeling (T-FSM), 2004

Integrated energy management system coupled with the above analytics and grid measurements

Sense → Monitor → Assess → Act → Sense.

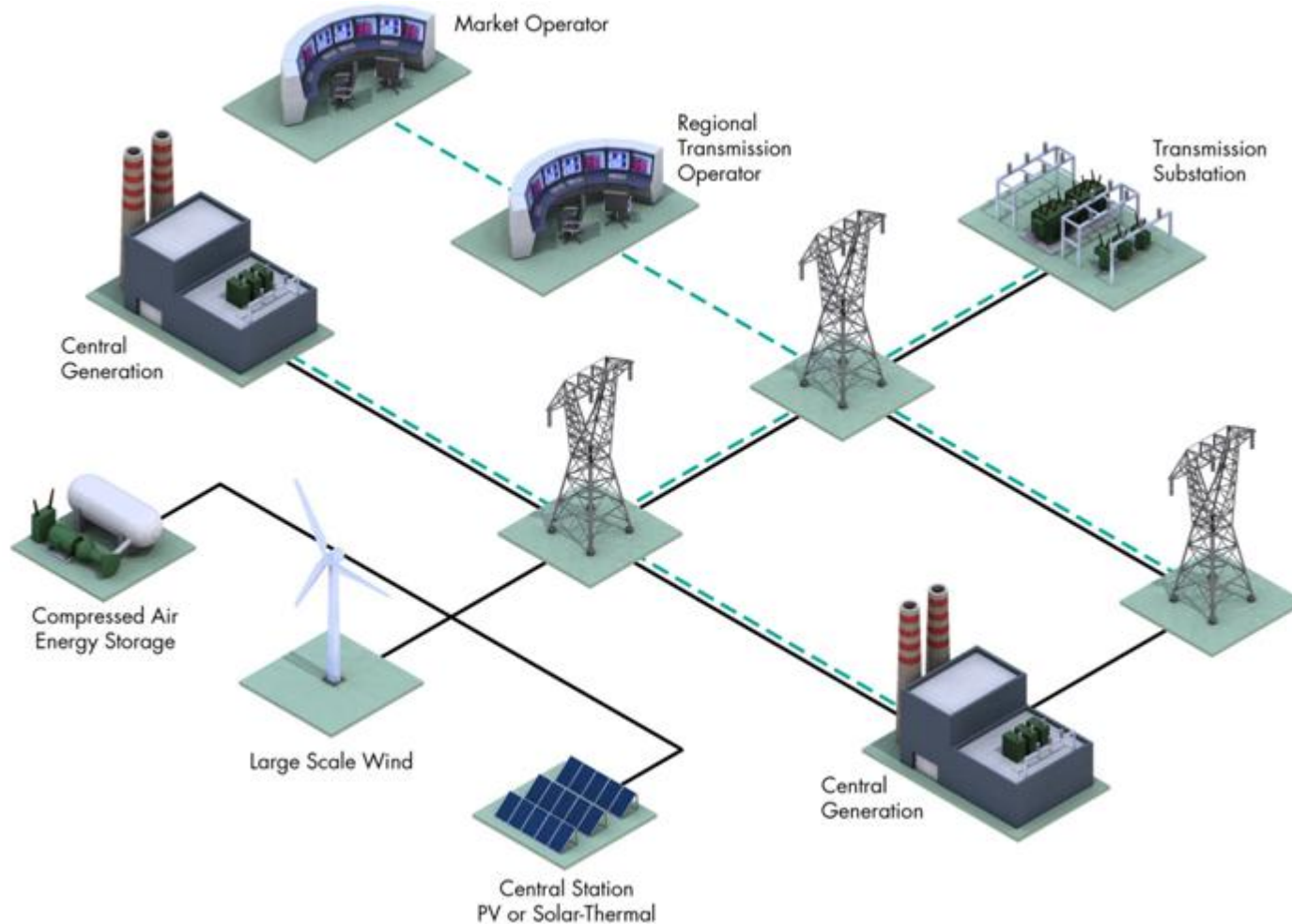

Integrated energy management system

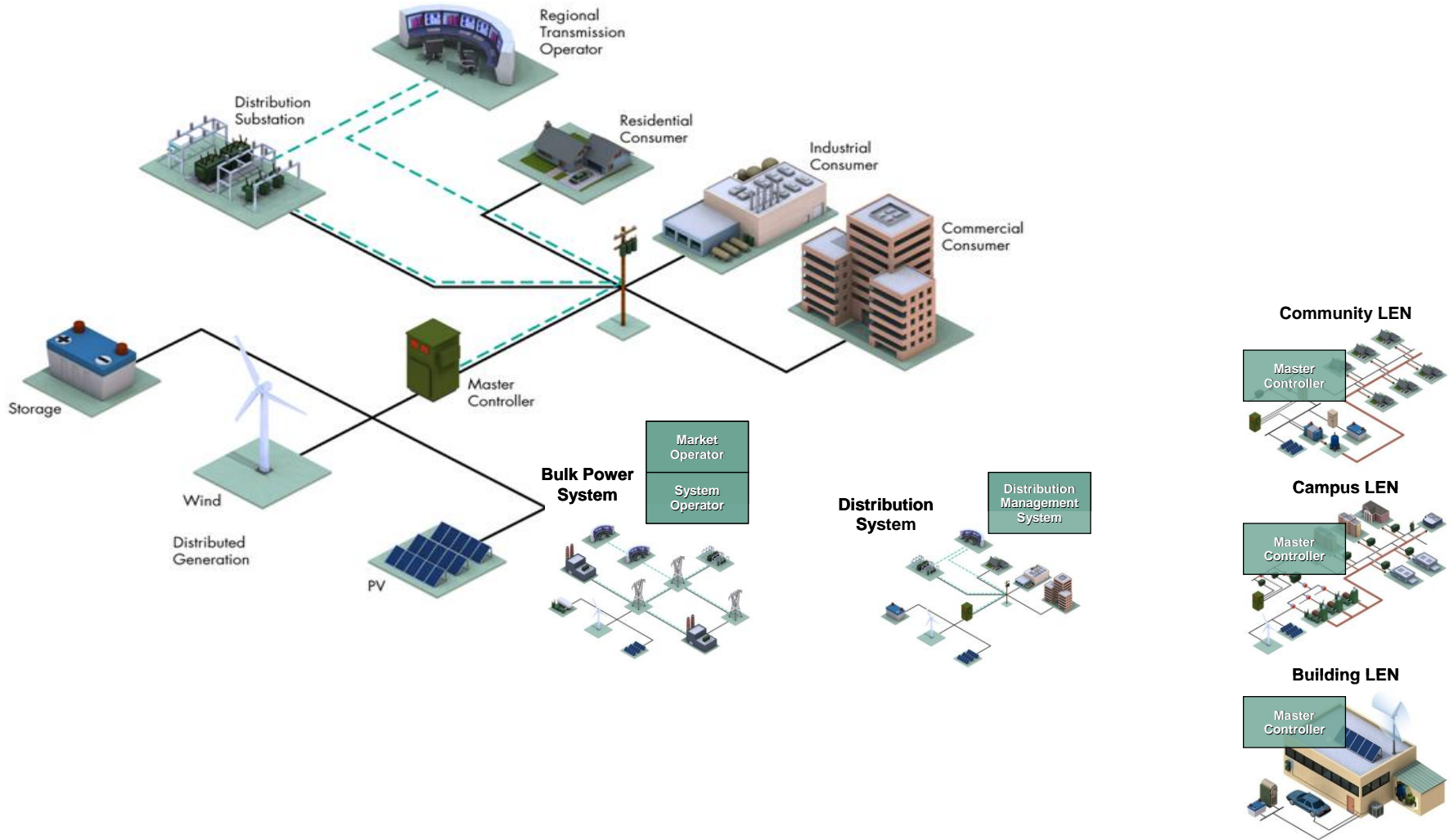

Advanced Control Functions

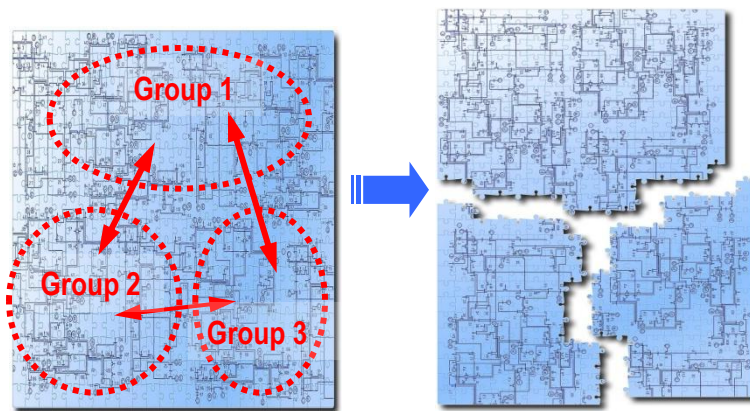
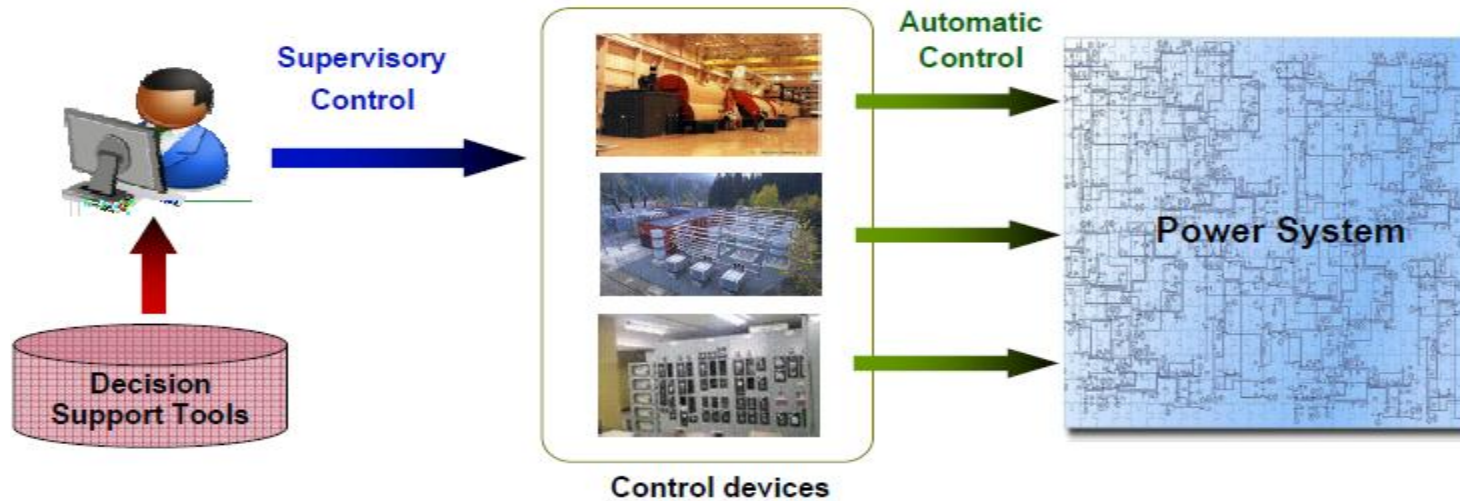

System Separation

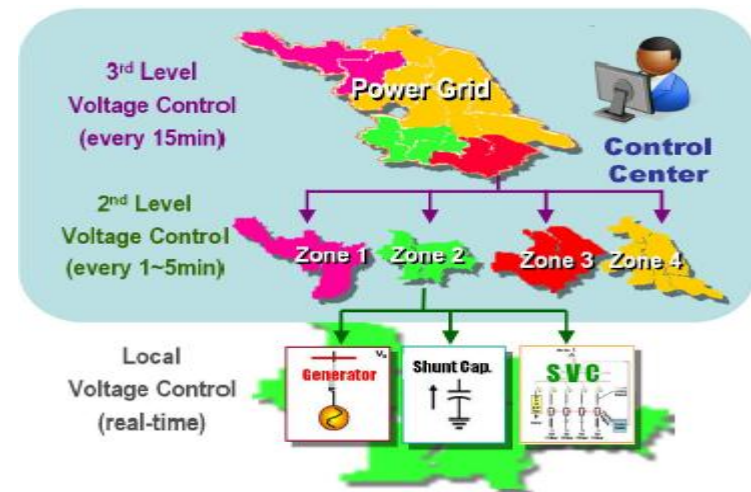

AVC

Collaboration to Develop Grid 3.0

- EPRI can be a catalyst in the development of Grid 3.0 by becoming a facilitator among the stakeholders leading to development of the architecture and functional specifications.
- That plan will develop a 24-month vision of a full architecture and a requirement driven specification.
- This will be conducted in an open environment such that the implementation and ultimate innovative development of products and systems can be conducted by vendors.
- It is critical that the industry respond to this call for action to embrace this innovation challenge to develop Grid Operating System 3.0.
- EPRI will provide seed funding for the first phase of this effort from its Technology Innovation Program.

Together...Shaping the Future of Electricity



EPRI

ELECTRIC POWER
RESEARCH INSTITUTE