



*EPCC 2011, Altea, Spain*

---

# Integrated Substation Data for Control Center Applications

Mladen Kezunovic, Ph.D., P.E.

*Department of Electrical and Computer Engineering*

*Texas A&M University*

*kezunov@ece.tamu.edu*



Existing EMS paradigm  
New EMS paradigm  
Data management  
Model management  
New applications  
Q/A

# OUTLINE

# Existing Paradigm

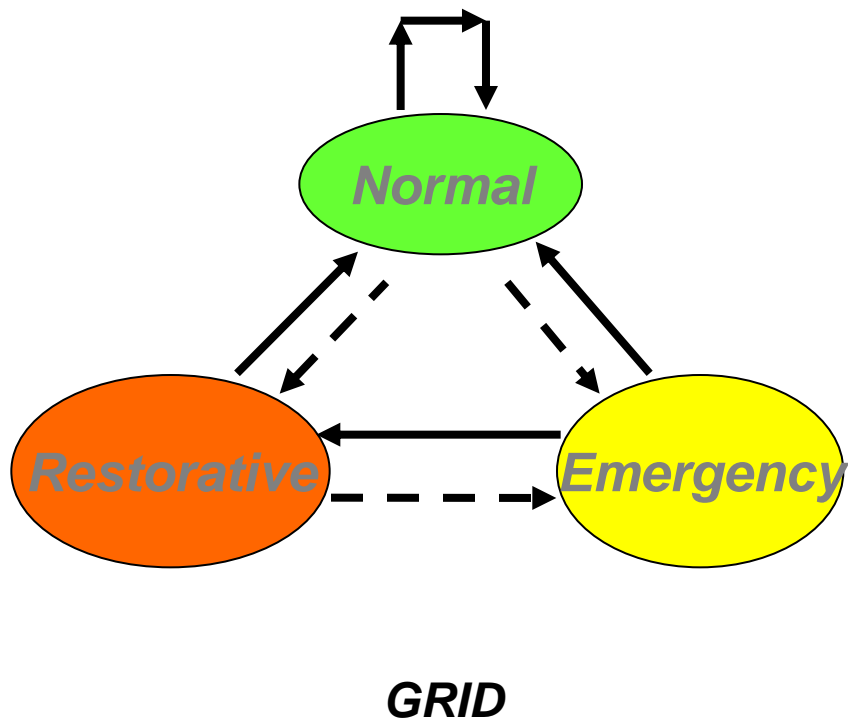

## Emergency

- SCADA Data
- N-1 contingency
- Protective relaying
- SIPS and islanding
- No operator action
- Market suspended
- Blackouts occur



# Emergencies

- *N-m*

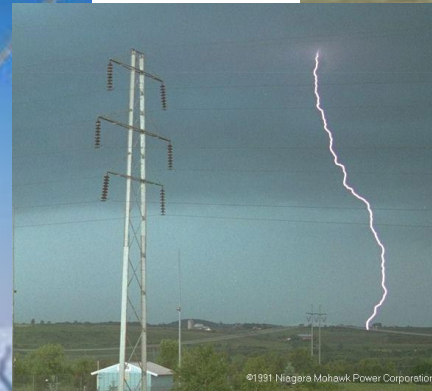

©1931 Niagara Mohawk Power Corporation



- *Cascading events*
- *Types of faults*
  - *Temporary*
  - *Permanent*



# New Paradigm

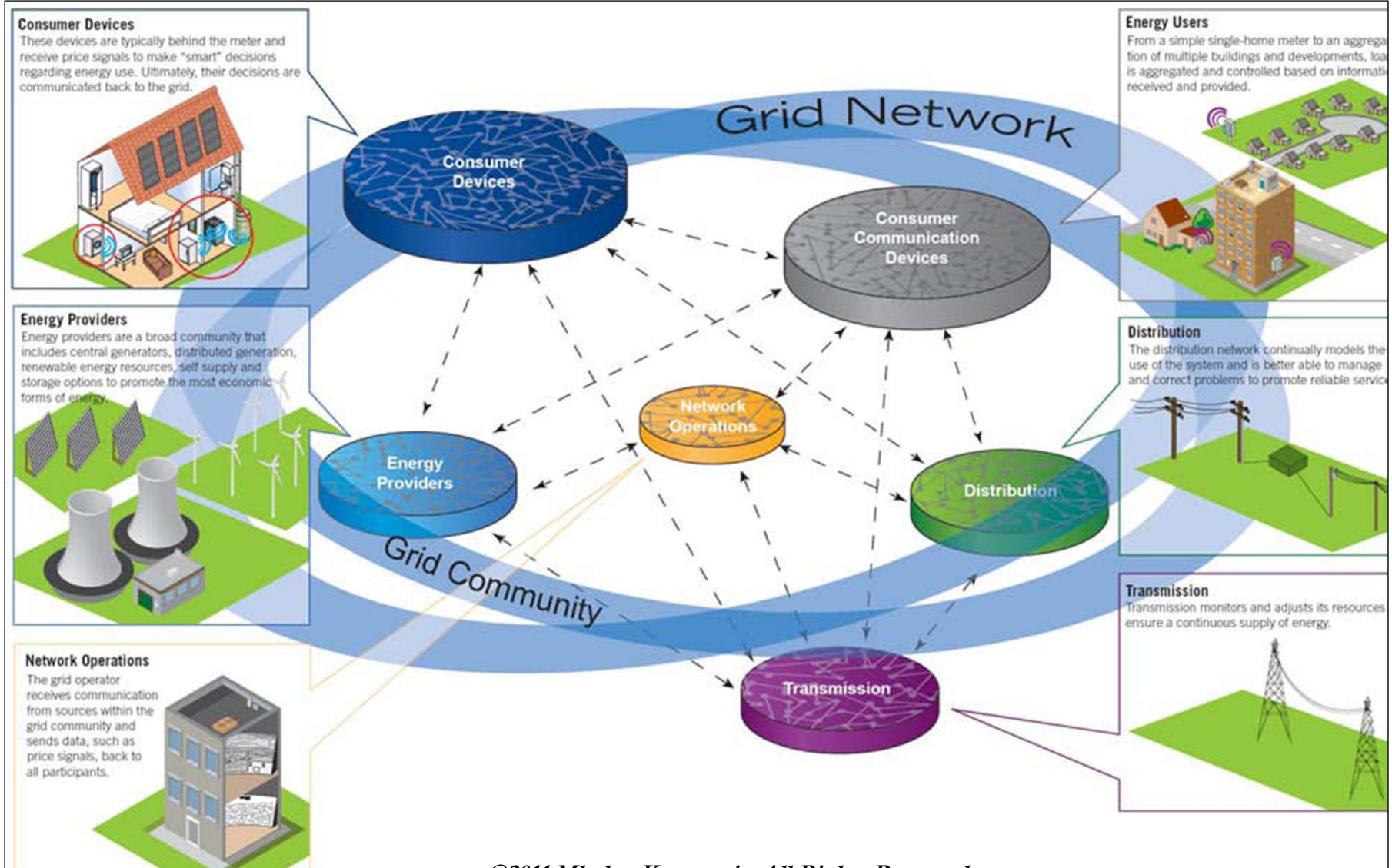





# Data Management



## Layout of typical substation equipment

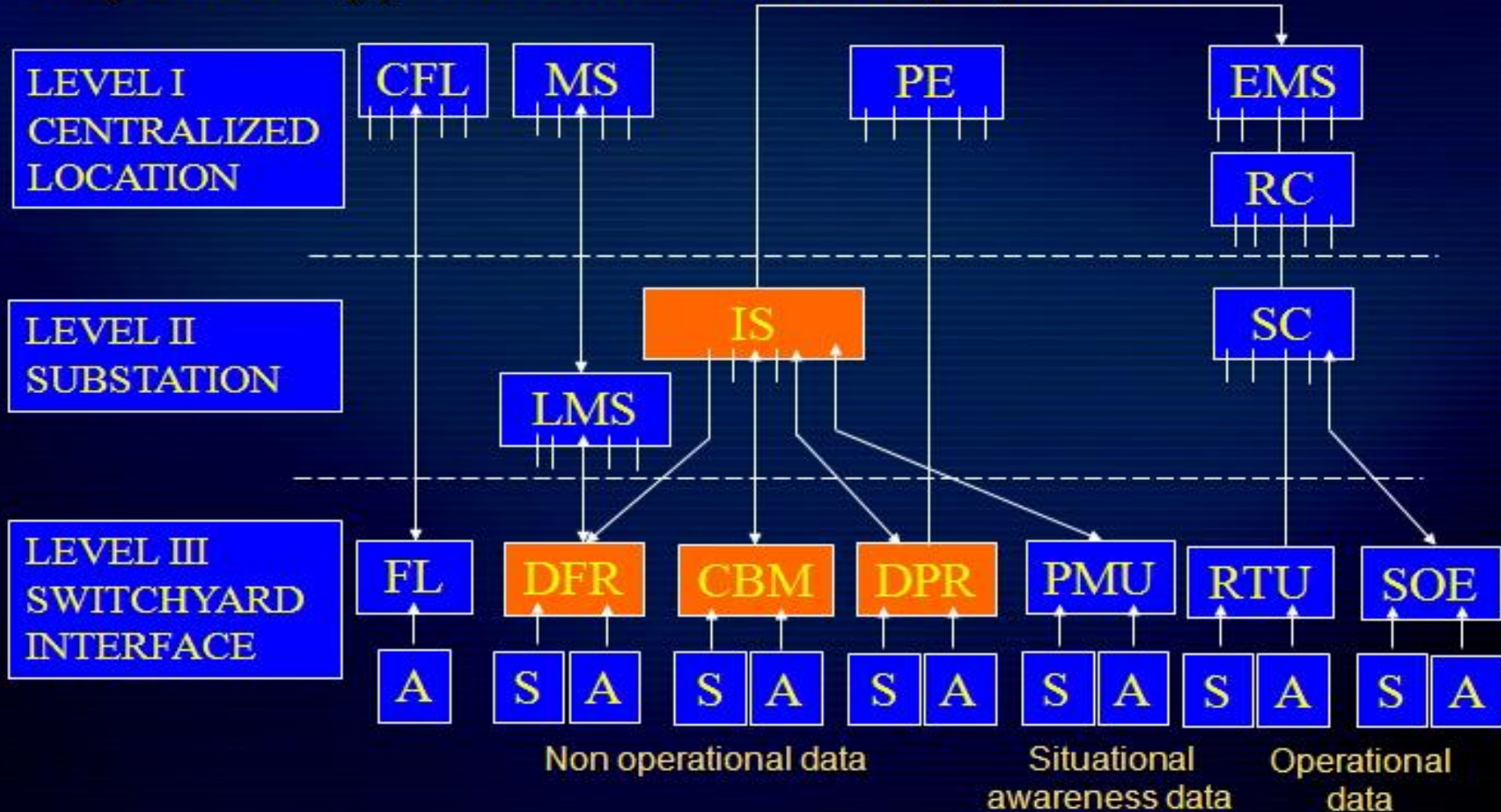



# Data Integration

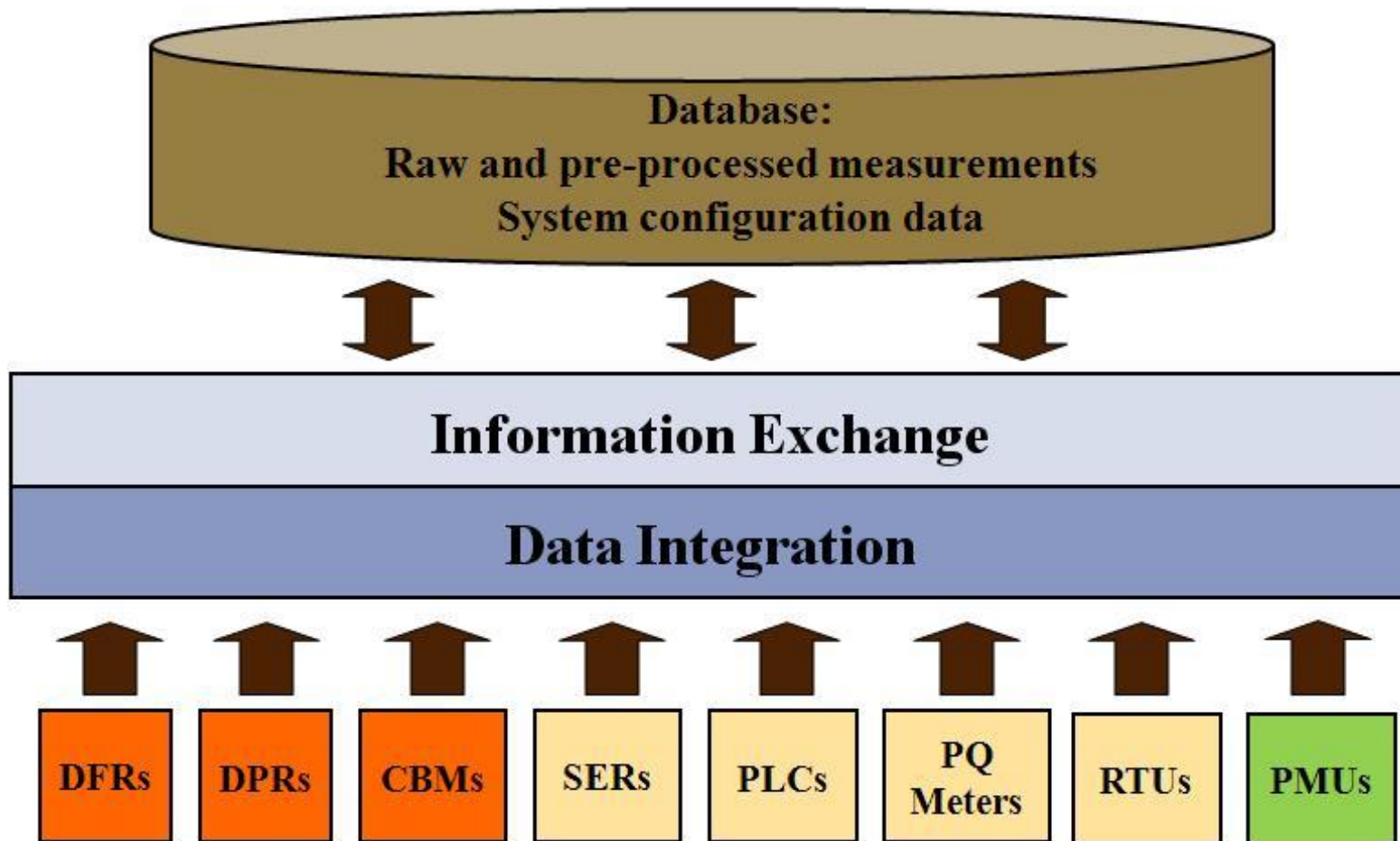



# Time synchronization

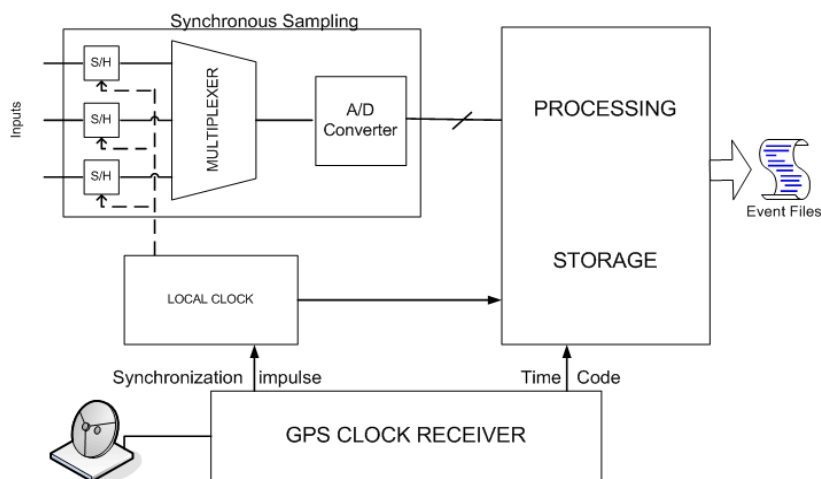

- Absolute time reference (time stamp)
- Relative time reference (samples, phasors/angles)
- Time scales ns, ms, s
- Synchronized sampling vs. scanning
- Synchronization per substation
- System-wide synchronization.



# Time synchronization

## IED GPS and data exchange wiring

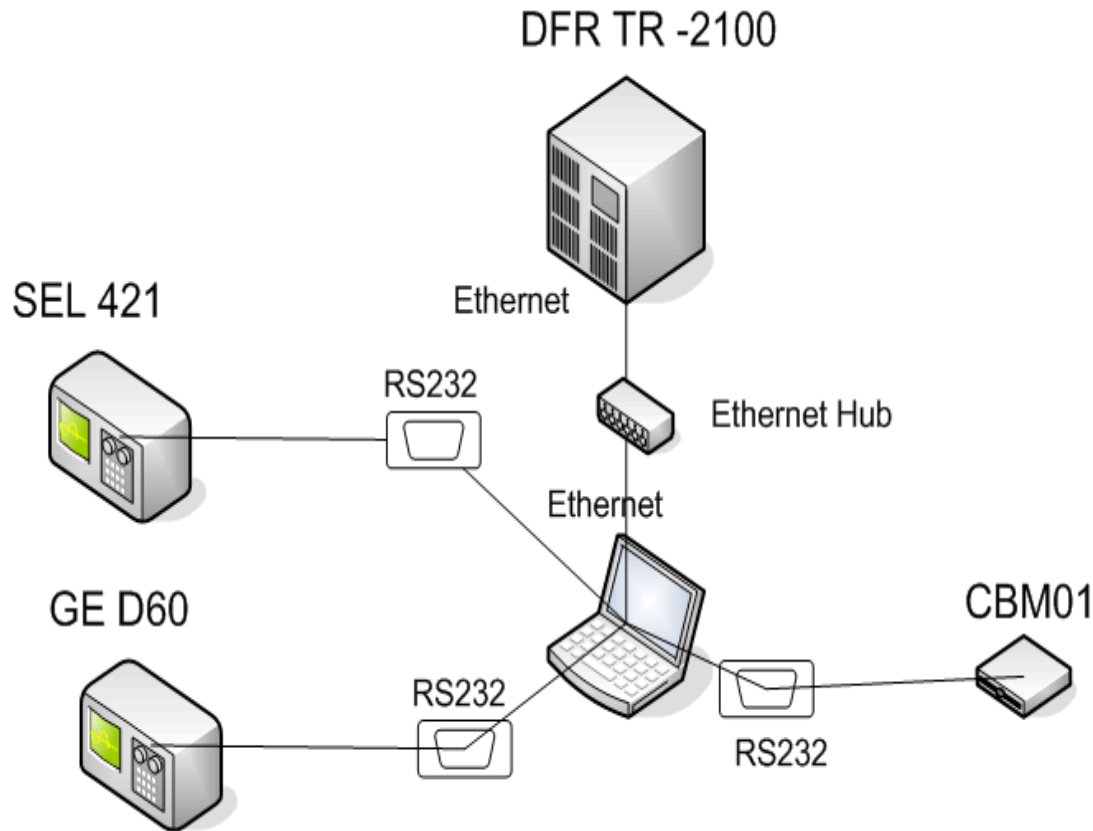



# Information Extraction

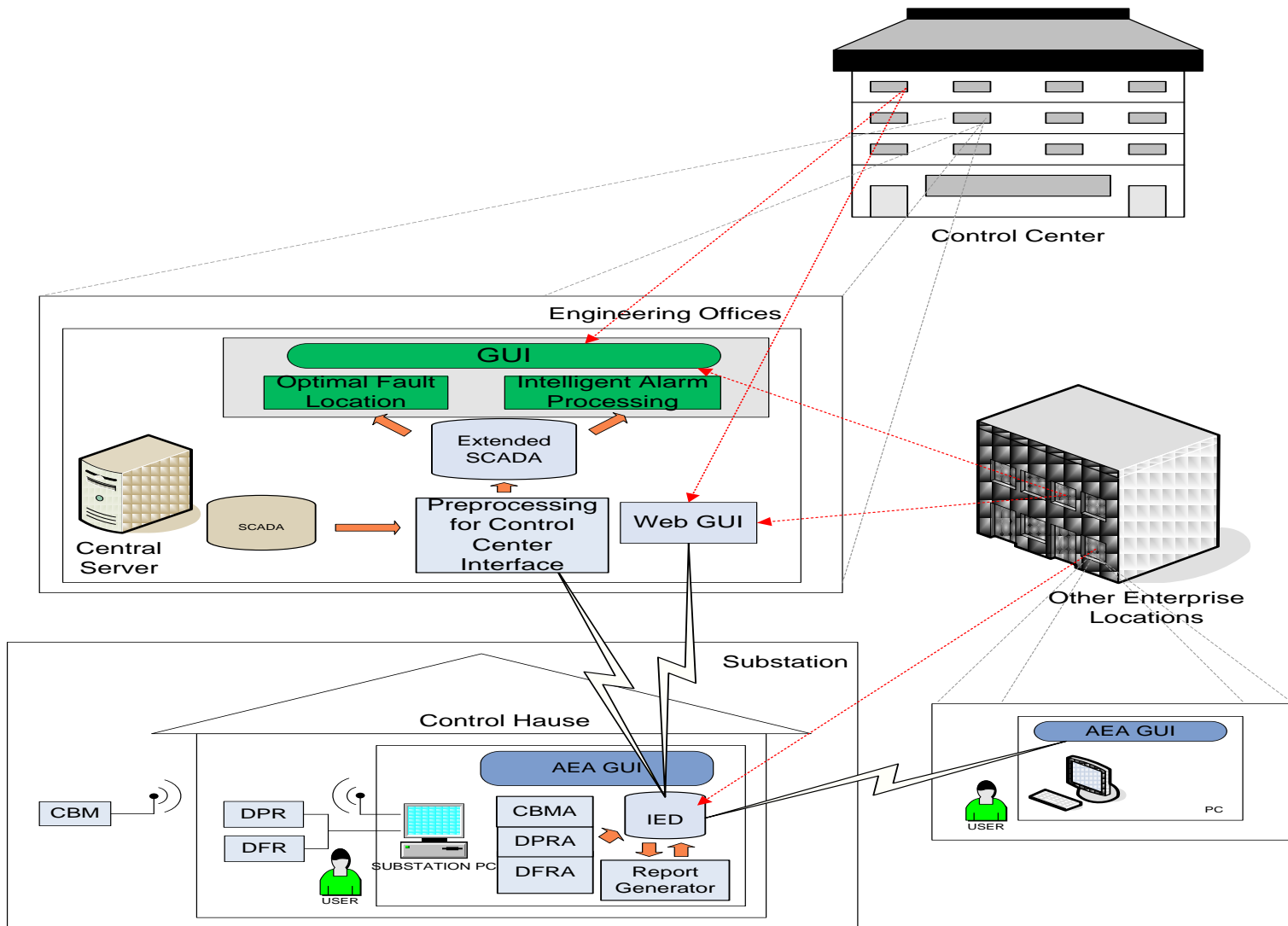



# Information Sharing

Engineer



Comprehensive Report

Dispatcher



Brief Report

Technician



Summary Report

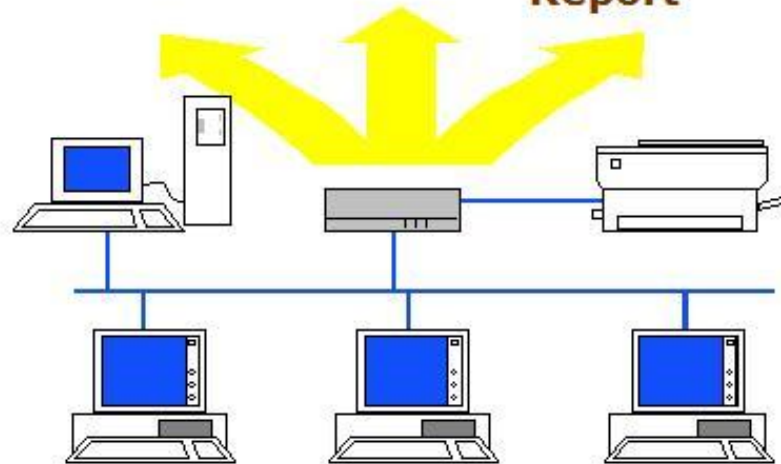



# Two-Model Paradigm

## Operations Model

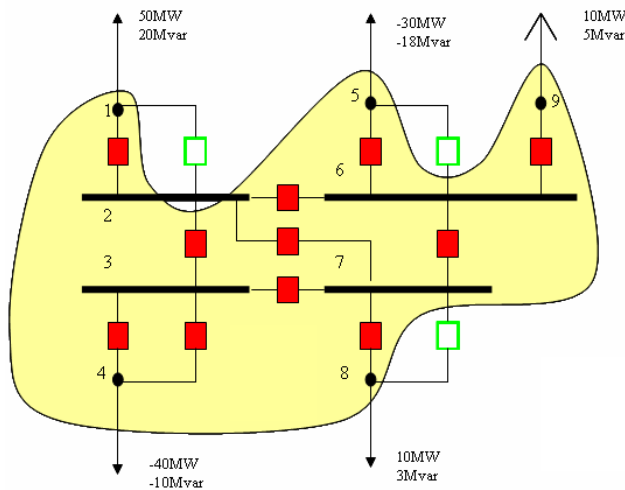

Physical System



## Planning Model

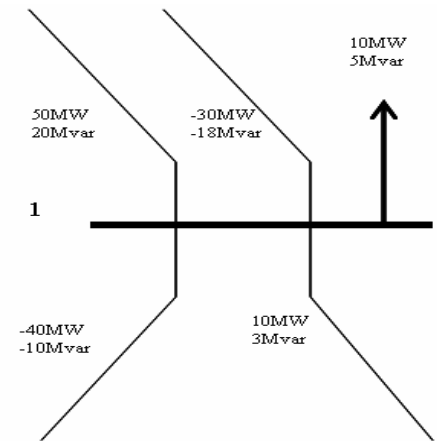

- During the 60s and 70s, the power industry decided to adopt different power system **models** for real-time operations and planning.
- This **two-model paradigm** continues **today**



# Matching of data and models

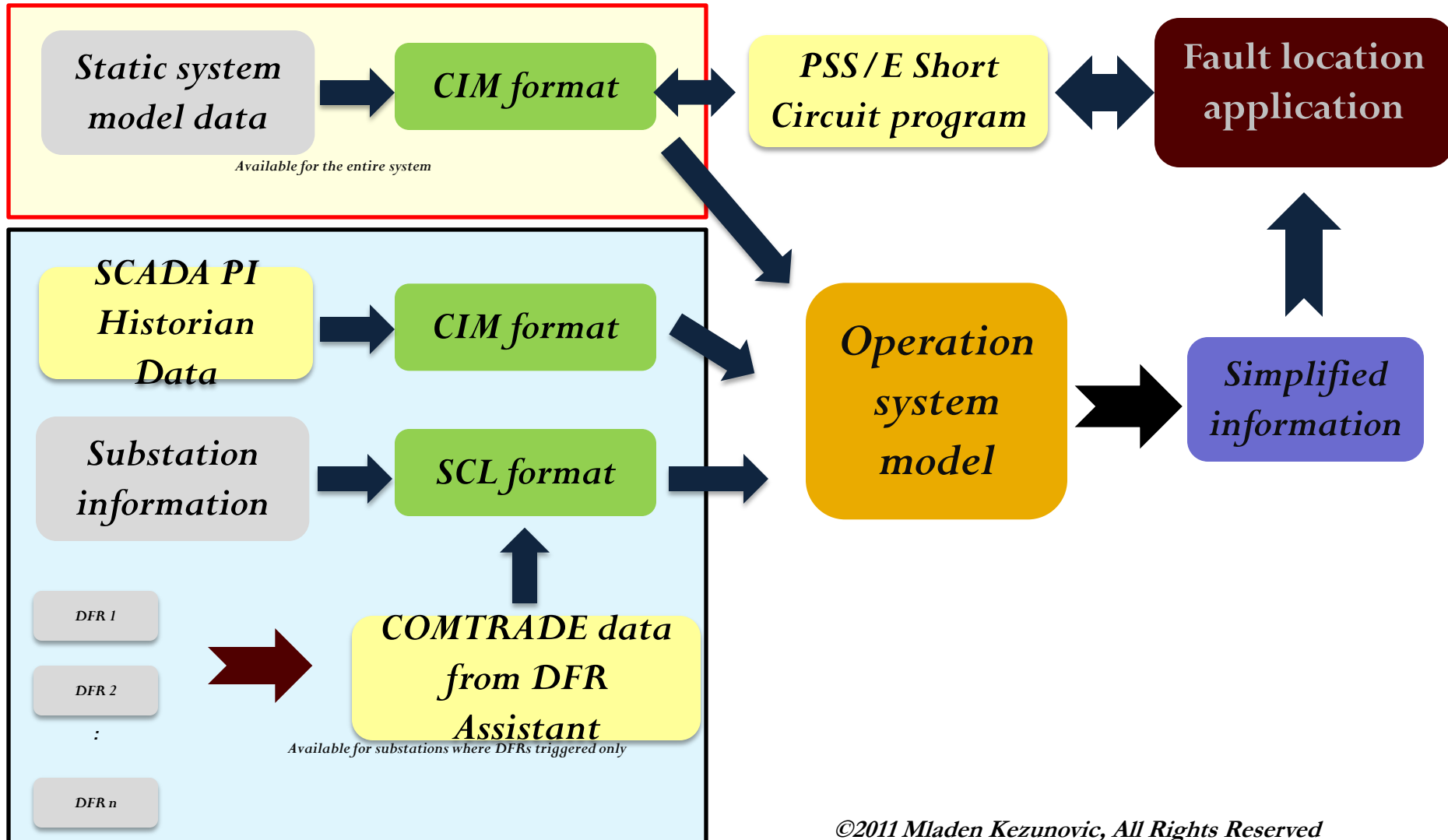



# Visualization

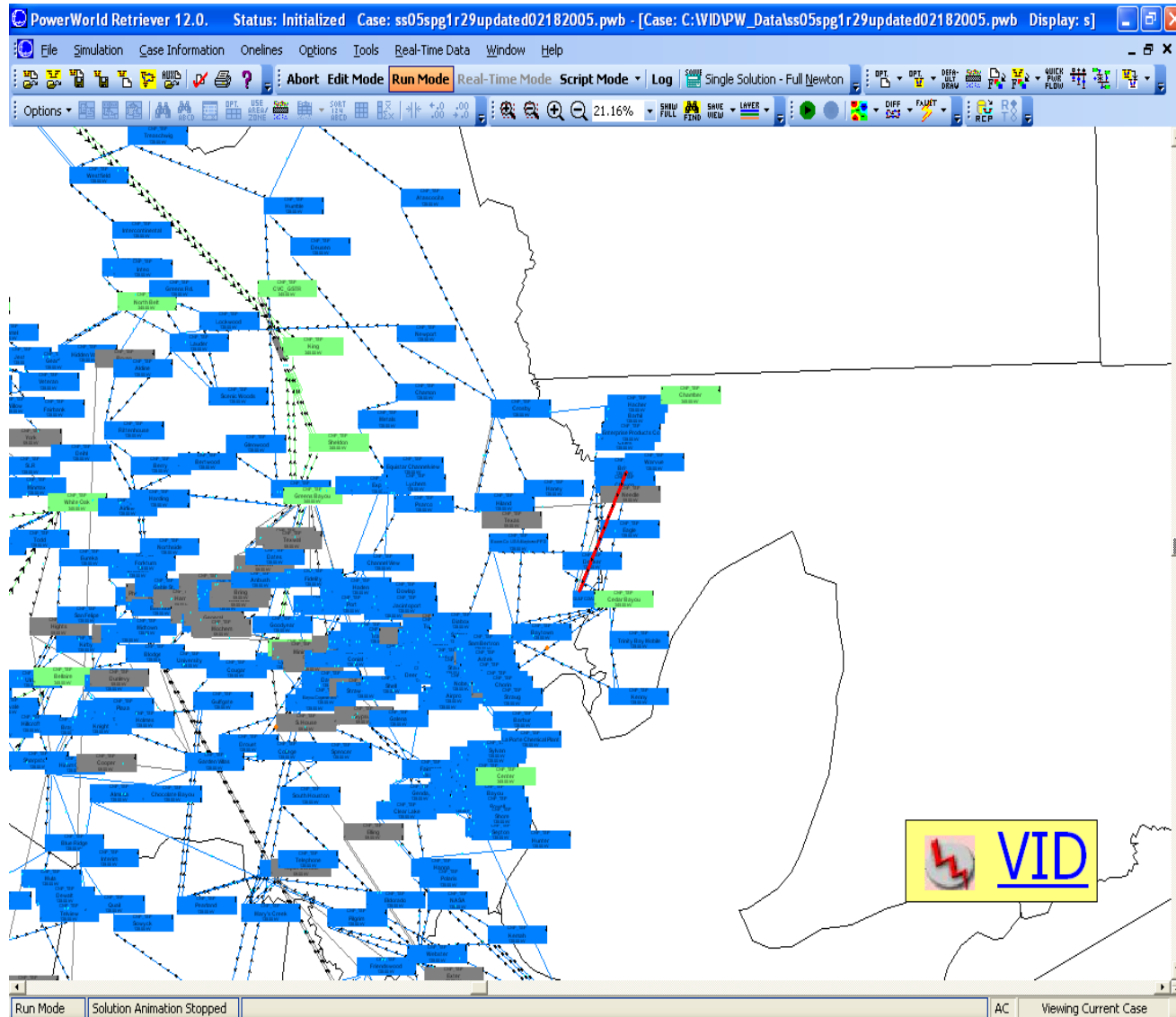



# Visualization

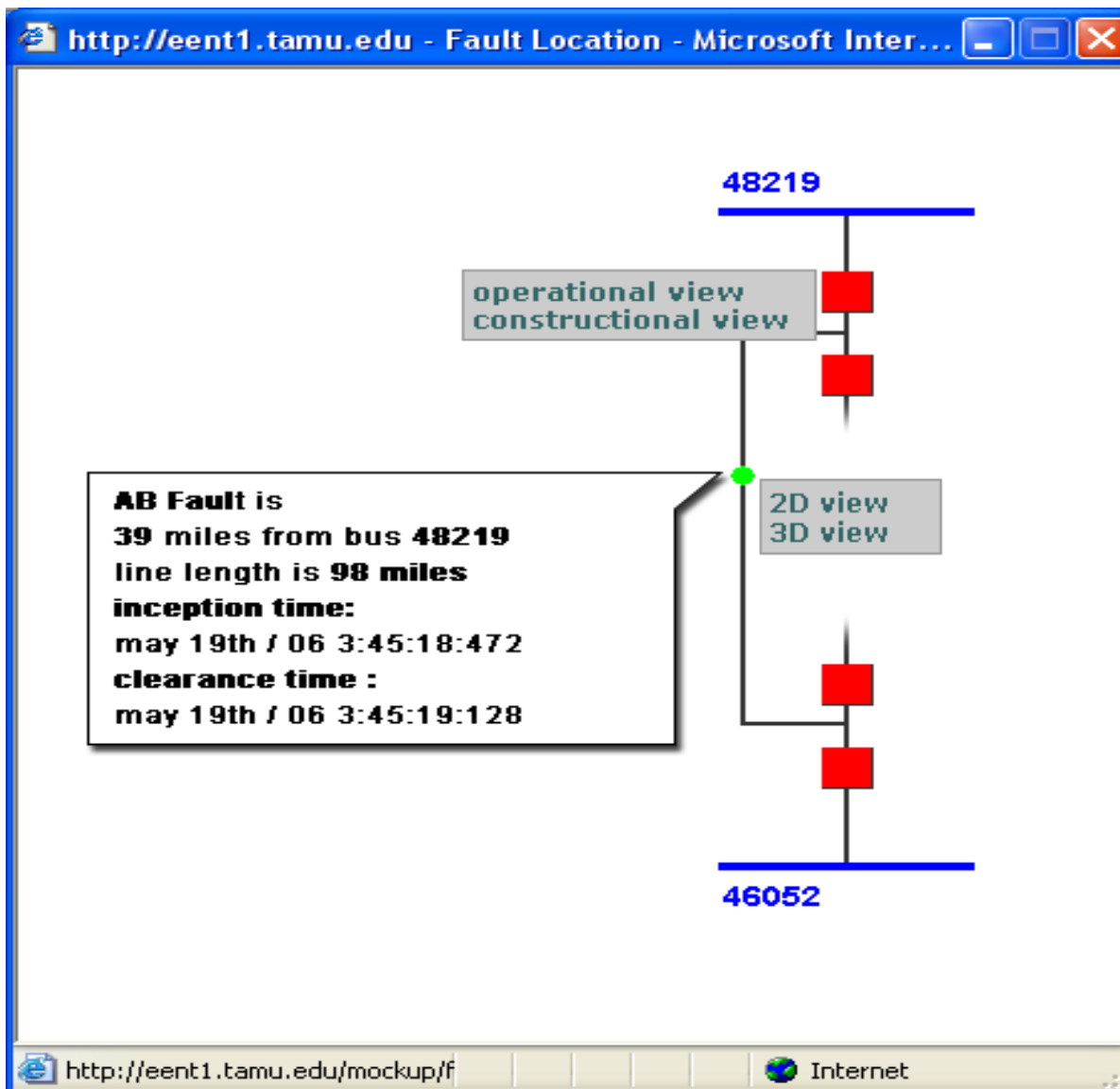



# Visualization



TEXAS A&M  
UNIVERSITY





# Visualization

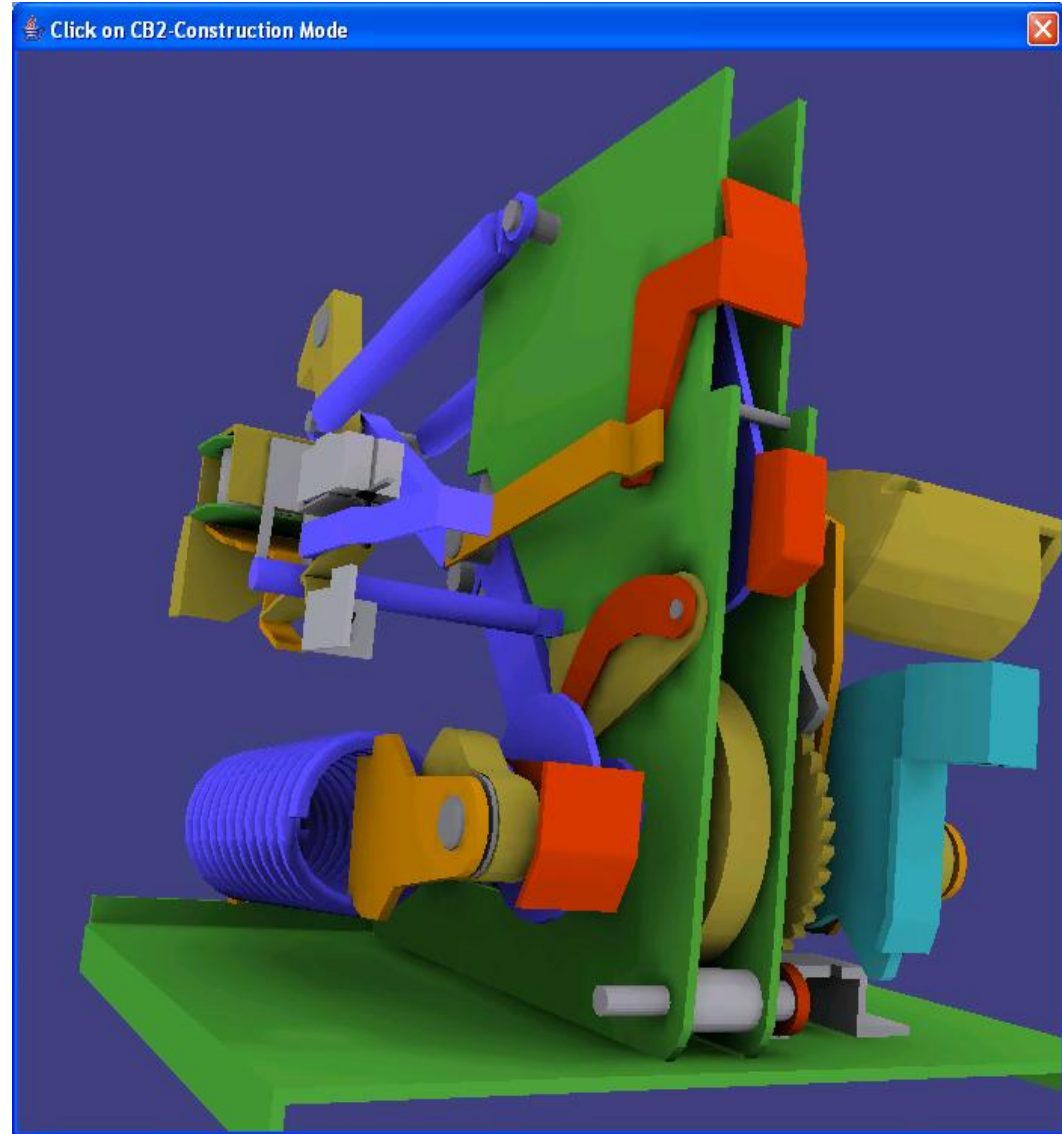
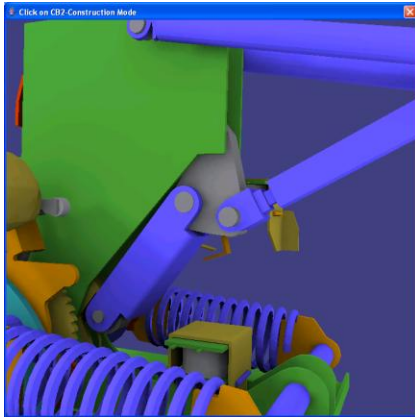



# New Applications

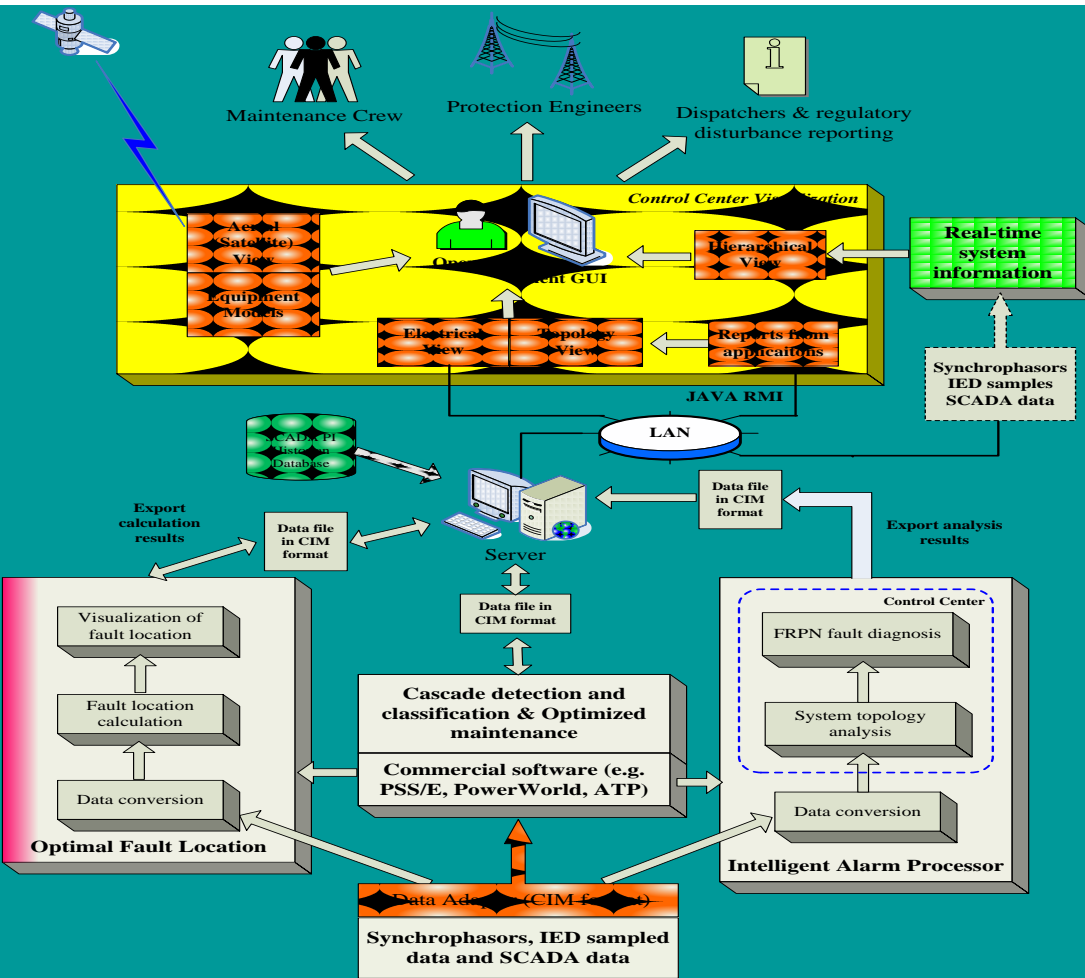

Distributed processing  
Centralized coordination

**Data:**  
High resolution at source  
**Information:**  
High context at destination

# ARCHITECTURE



# New Applications

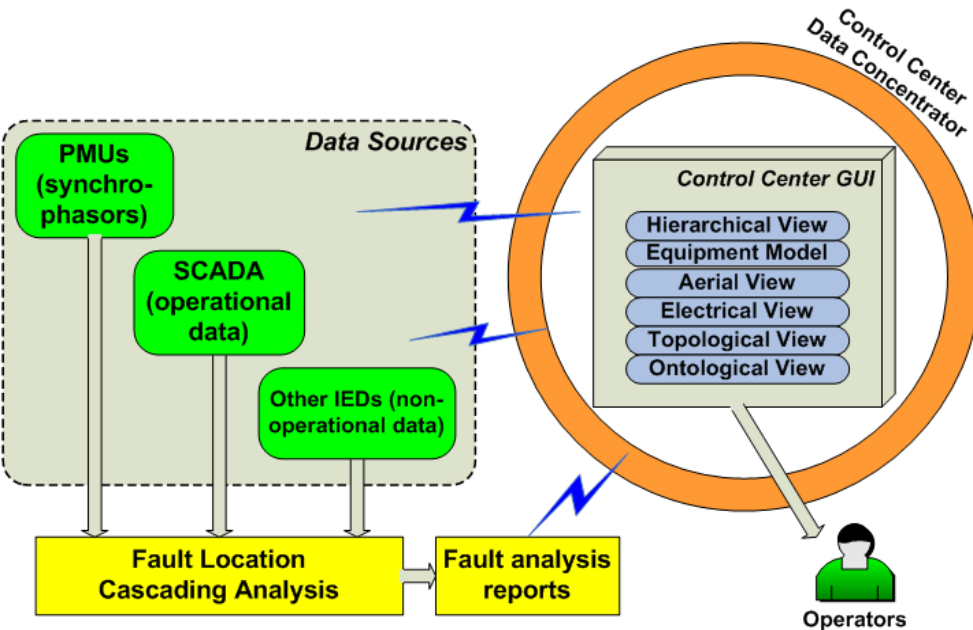

Enhanced view of the system:  
data integration

Improved handling of  
emergencies:  
Economic Alarm Processor

# OPERATIONS



TEXAS A&M  
UNIVERSITY



# Questions?