

**11th EPCC
Altea, Spain
May 22-25 2011**

***System
Awareness -
How to detect
system states***

carsten.roggatz@dutrain.de

Training tasks

Online detection of system states based on operational criteria

Decision making:

normal / **alert** / **emergency** / **blackout** state

Internal / Cross border incidents

Communication, Coordination and Cooperation

Use of ENTSO-E **R**egional **A**larm and **A**wareness **S**ystem
(RAAS) – “Traffic Light”

Operational criteria

Classical

Voltage	minimum / maximum
Current	maximum
Short Circuit	minimum / maximum
N-1	
Frequency	e.g. $50.5 < 50.2 < f_{\text{nom.}} < 49.8 < 49.5$

Extra

- Reserve power primary / secondary / tertiary
- Islanding
- Internal / Cross border incidents
- Higher level information, e.g. Load / Generation shedding

RAAS-Systems

Real life RAAS

- Based on ENTSO-E standards
- Manual setting of system state / Reason sent by E-Mail afterwards

Simulation

Training RAAS

- “pin wall” for system states in training sessions
- Manual setting of system state

Trainer’s RAAS

- ***Automatic*** setting of system state

Training RAAS with additional information

Detailed technically driven view on the system state definition

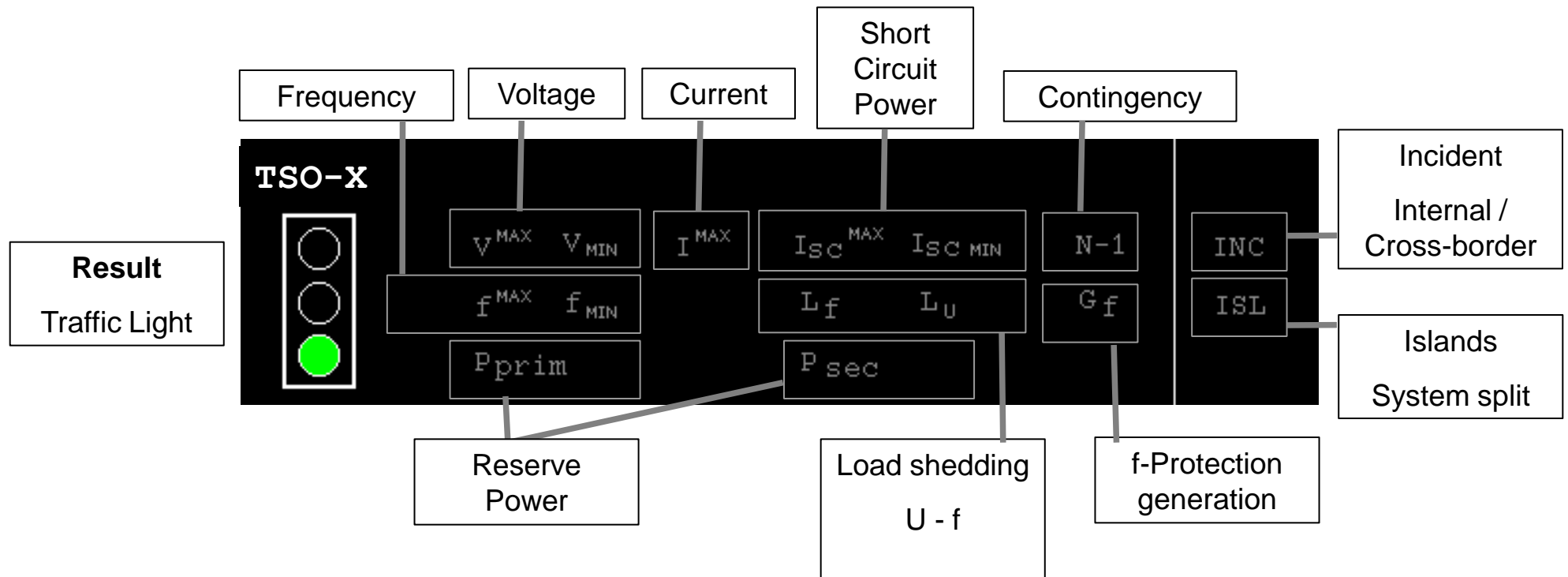

Each criteria can be assigned to a system state

Example Training RAAS for TSO-X

Situation:

Contingencies and low voltages in a part of the control area

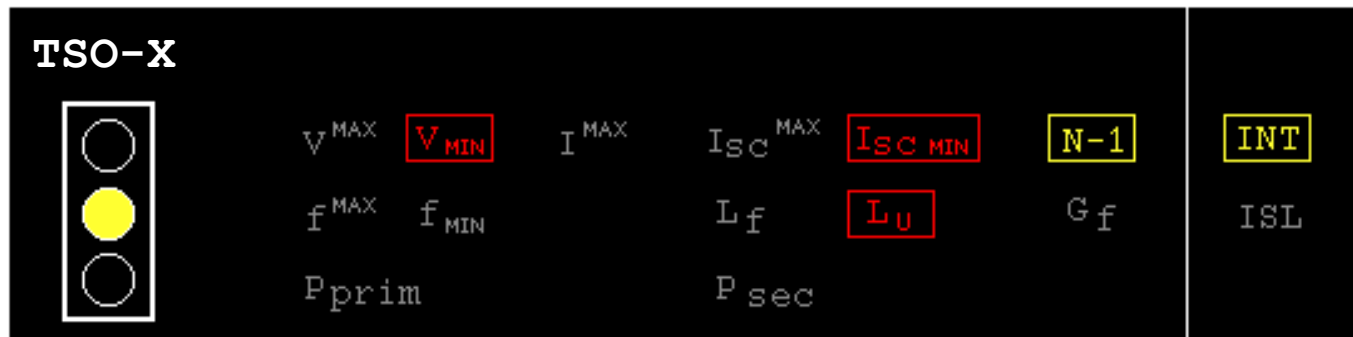

Which colour of traffic light should be set?

Alert or **Emergency** or **Blackout**?

Remedial measures to be taken?

Trainer's RAAS

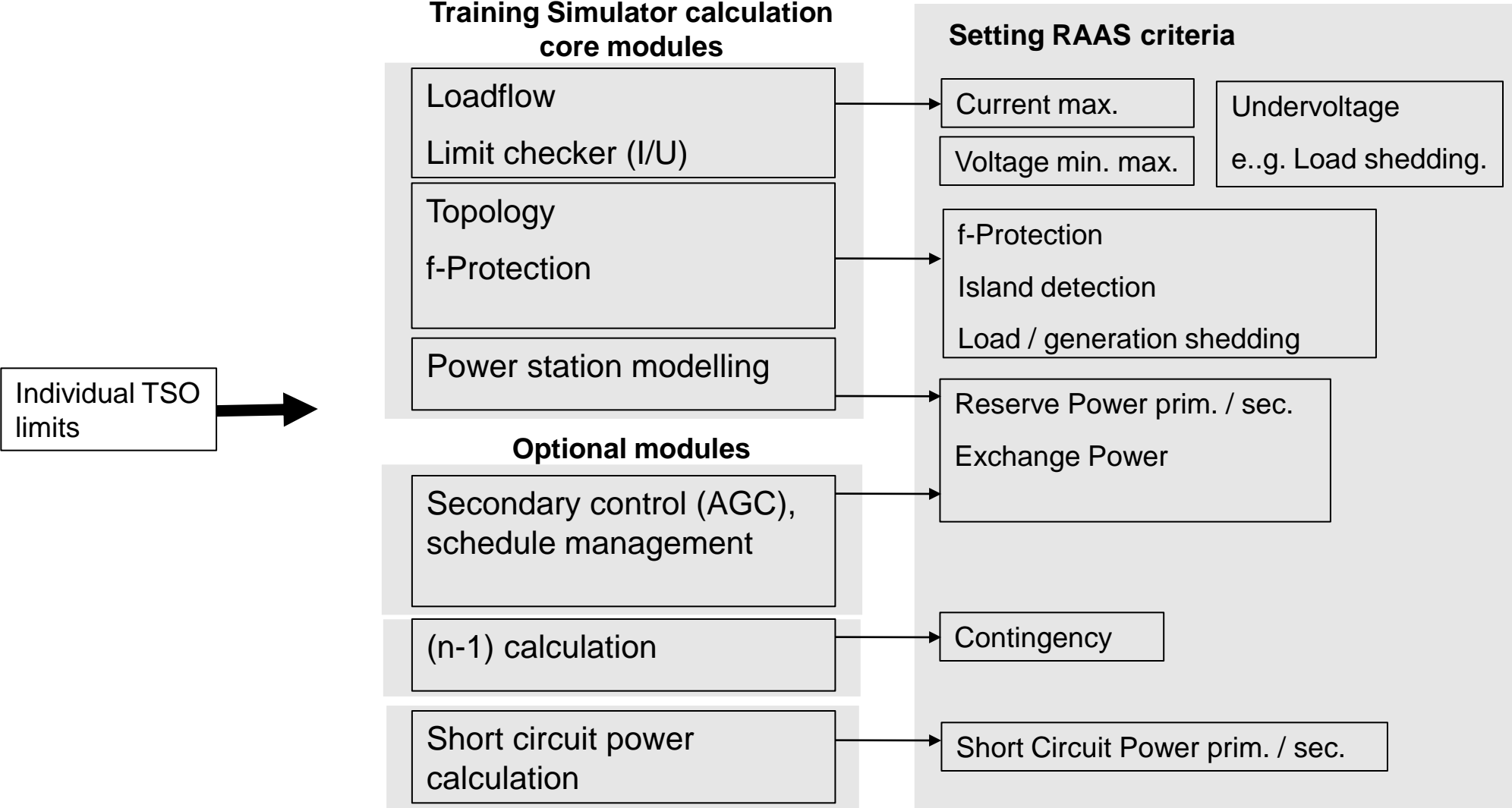

System states in a multi area control centre environment

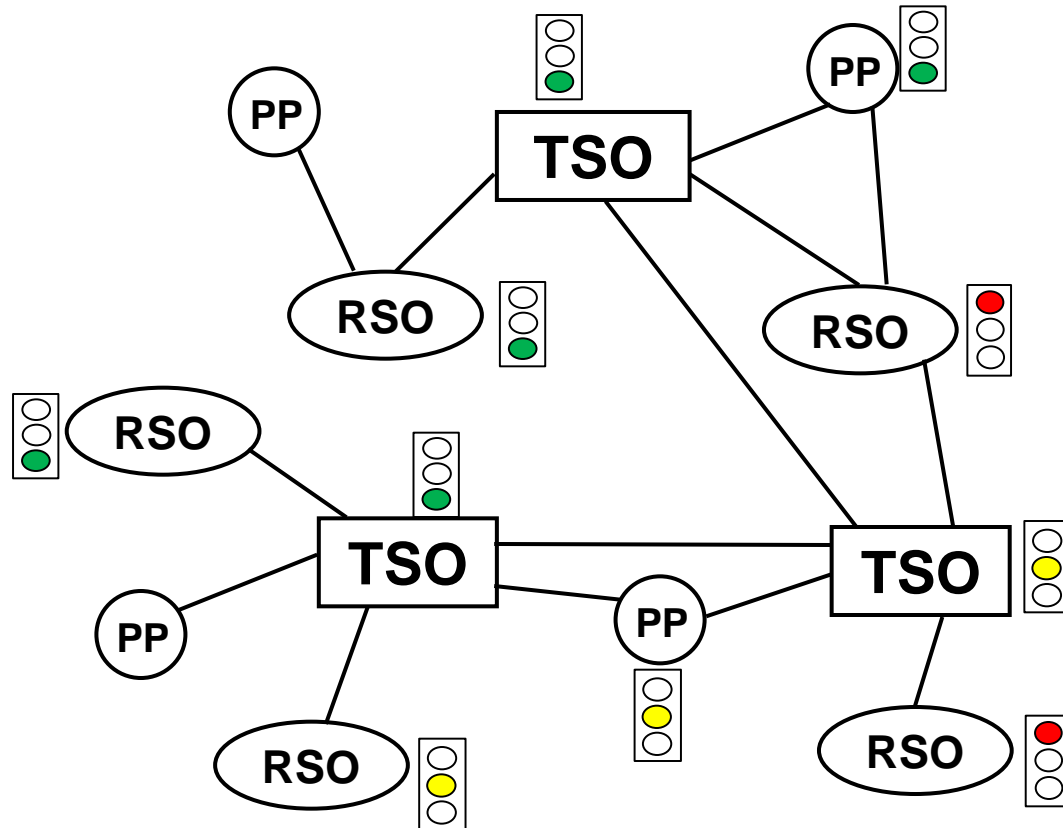

PP:	Dispatch centres
RSO:	Regional systems